

The Pink Hip Kit[®]

Postless Hip Positioning System

Instructions for Use

Device Description

The Pink Hip Kit is designed to be used with the Smith and Nephew Hip Positioning System and prevents movement of the patient on the OR table during arthroscopic hip procedures.

The Pink Hip Kit is single-use and discarded following completion of the surgical procedure.

The Pink Hip Kit (*Figure 1*) consists of the following components:

- | | |
|-------------------------------|-------------------------------|
| A. Head Positioner (1) | D. Lift Sheet (1) |
| B. Pink Hip Pad (1) | E. Armboard Straps (2) |
| C. Body Strap (1) | F. Arm Protectors (2) |

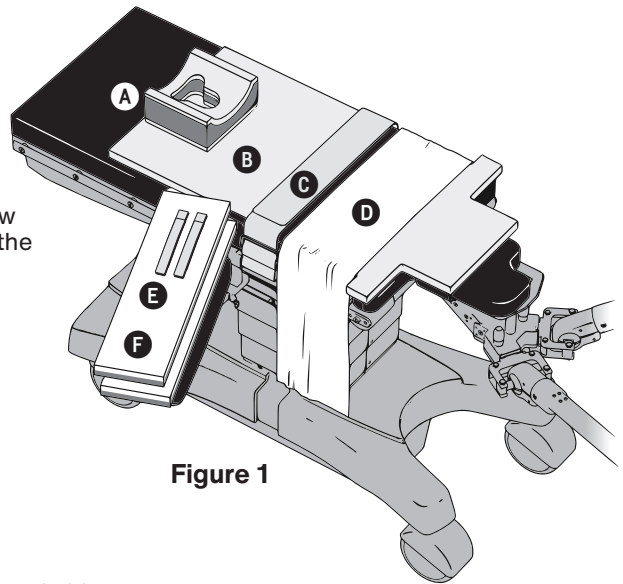

Figure 1

Intended Use

The Pink Hip Kit is intended to be used prior to and during arthroscopic hip procedures to prevent movement of the patient on the OR table.

Warnings

- Follow your facility's policies and guidelines for frequency of patient monitoring. Check for skin integrity and proper circulation. Product is to be used by a licensed medical professional only.
- Before using The Pink Hip Kit, ensure the OR table pad is securely affixed to the OR table.
- During all handling and storage of The Pink Hip Kit, assure that the Pink Hip Pad is flat. Do not roll or fold.
- Make sure that the patient's skin is in direct contact with The Pink Hip Pad throughout the procedure.

Instructions

1. Refer to the Smith and Nephew Hip Positioning System Instructions For Use for system setup information.
2. Place the Pink Hip Pad on the OR table so that the alignment tabs line up with the Smith and Nephew Supine Table Attachment. (*Figure 2*) The text "This Side Up" should be facing upwards on the white Velcro straps located on the Pink Hip Pad.

CAUTION: Make sure that The Pink Hip Pad makes direct contact with the surface of the OR table pad.

3. Attach all white Velcro straps to the OR table rails by placing the loop portion of the tab down between the table and the accessory rail, then upward over the outside of the rail and affixing the hook portion of the Velcro closure over the loop portion. (*Figure 3*)
4. Affix the wide purple pad strap under the surgical table attachment by first placing the portion of the strap without Velcro underneath the table attachment and overlapping it with the remaining end of the strap, securing the Velcro to ensure a snug fit. (*Figure 4*)
5. Place the Head Positioner on the Pink Hip Pad near the edge furthest from the hip attachment in a location sufficient for patient head placement. (*Figure 1*)
6. Center the Lift Sheet over the pad just above the alignment tabs. (*Figure 1*)

CAUTION: The lift sheet should cover only the portion of the pad that will address the small of the patient's back (between the scapulae and sacrum).

Figure 2

Align the tabs of the Pink Hip Pad with those of the Table Attachment.

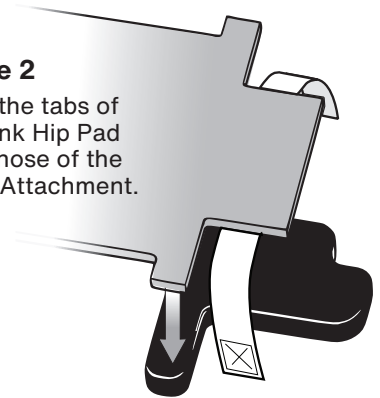

Figure 3

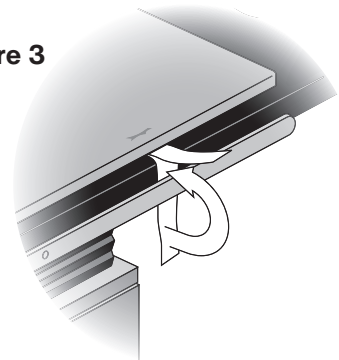
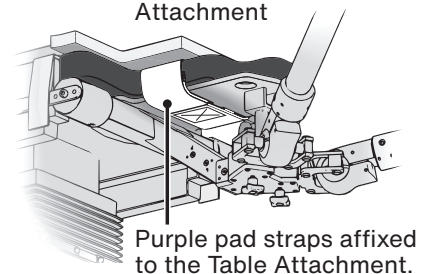
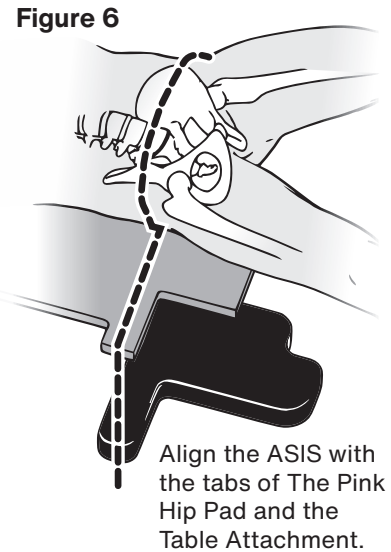
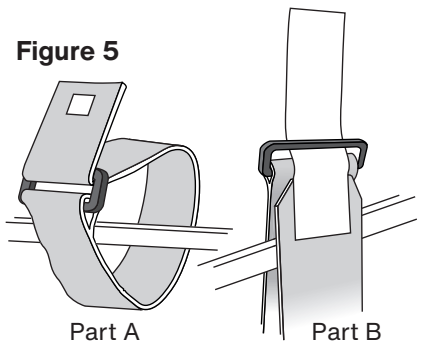

Figure 4 View from under Table Attachment



Purple pad straps affixed to the Table Attachment.

7. Secure both portions of the two-part body strap to the accessory rails:
 - Identify each portion of the strap — Part A has a small Velcro square and Part B has a long Velcro tab. (Figure 5)
 - Beginning with Part A, orient the strap so that the small Velcro square is facing outward, away from the table pad. Draw the end of the belt up between the table and the accessory rail and slide the plastic buckle down over the end of the strap. Feed the strap through the buckle until it is snug to the accessory rail and lay the free end over the table.
 - Repeat the procedure with Part B of the strap on the other side of the table, ensuring that the hook side of the long Velcro tab is facing inward toward the table pad.
 - Join straps together with the long Velcro tab of Part B on top of Part A.
8. Transfer the patient to the Pink Hip Pad. Position the patient as follows:
 - The patient's anterior superior iliac spine (ASIS) should be positioned directly on the alignment tabs. (Figure 6)
 - Approximately six inches of the Pink Hip Pad will extend beyond the patient's gluteal crease.
 - Ensure that the shoulders do not extend past the top edge of the Pink Hip Pad, to maximize skin contact.
 - The skin of the scapular region and sacrum must contact the surface of the Pink Hip Pad.
 - If needed, utilize the lift sheet to carefully LIFT the patient up off of the pad to reposition. Do not drag the patient on the pad. Make sure the Pink Hip Pad remains flat at all times.
9. Place one Arm Protector on the arm board of the OR table on the opposite side of the operative hip with the white DermaProx facing upward, contacting the patient's skin.
10. Place the patient's arm on the Arm Protector with the palm up and secure it with an Armboard Strap.
11. Lay the other arm across the patient's chest, ensuring that the hand is in a natural, anatomically-correct position.
12. Place the remaining Arm Protector between the patient's arm and chest, parallel with the patient's forearm with the white Dermaprox layer facing upward against the patient's forearm. Center the Arm Protector under the patient's hand and fold it back over the hand, sandwiching the patient's hand within the white DermaProx layer of the Arm Protector.
13. Affix the purple two-part Body Strap around the patient, over the patient's elbow, arm and Arm Protector, securing it with the Velcro closure.



See Completed setup illustration for reference. (Figure 7)

Figure 7
Completed setup with properly positioned patient.

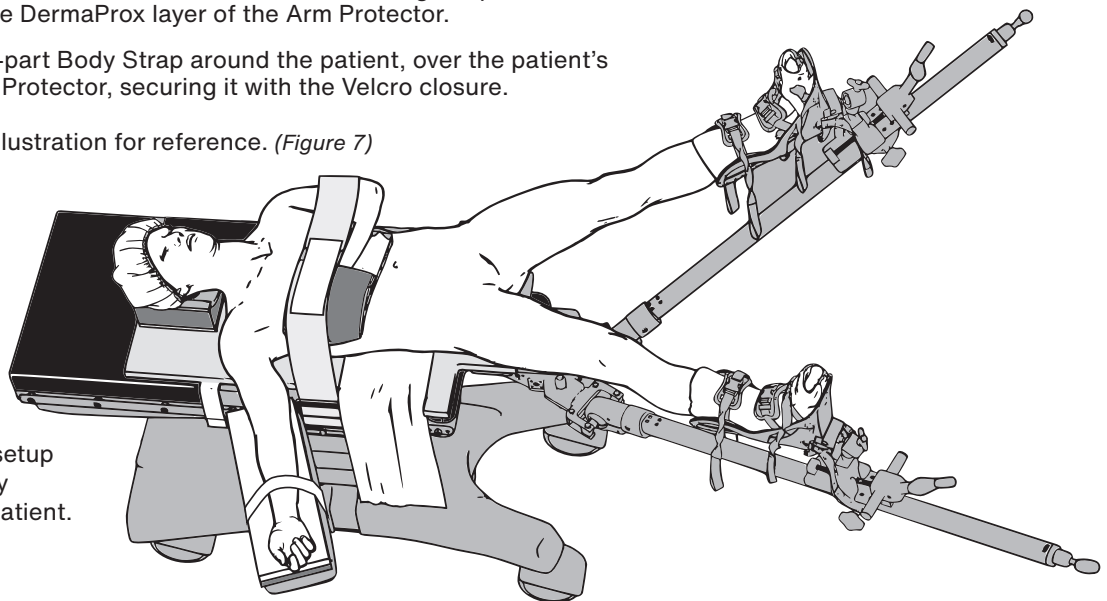

XODUS MEDICAL
Making Surgery Safer™

702 Prominence Drive
Pittsburgh, PA 15068 U.S.A.

Tel: 724.337.5500
Fax: 724.337.0555



xodusmedical.com
info@xodusmedical.com



FDA REGISTERED
ISO 13485 CERTIFIED

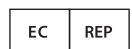

EMERGO EUROPE
Prinsessegracht 20
2514 AP The Hague
The Netherlands

LITIFUPP008 R3 7/11/19