

# INSTRUCTIONS FOR USE: SAVATTA PINK LAT PACK™

Kit may not include all items

1. Make sure O.R. table is level and in standard position. If using supplemental Pink Pad XL, lay down Pink Pad XL on the upper half of the O.R. table and attach the Pink Pad XL to the O.R. table according to the Pink Pad XL Instructions For Use.
2. Lay Adjustable Lateral Headrest on O.R. table relative to where the patient's head will lay. The hole in the headrest is where the patient's ear should end up. The taller part of the headrest should encompass the back of the patient's head. (figure 2-2)

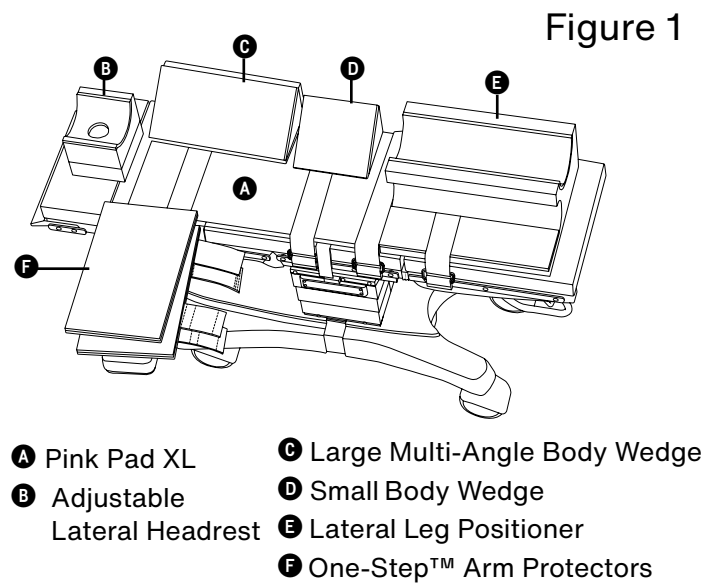

3. Lay 35° portion of the larger wedge on O.R. table, relative to where the patient's back will be. Begin positioning the patient by laying them on the larger body wedge. (figure 1-C)
4. Put the smaller wedge right below the larger wedge so that it goes under the patient's buttocks. Make sure the patient is supported in the lateral position. (figure 1-D)
5. Place the leg that is under the patient's body into the Lateral Leg Positioner and lay the top leg into the remaining part of the holder so that the hips are in the correct position. (figure 2-5)
6. If using Arm Board Pads, place DermaProx™ Lined Arm Board Pads on arm board and lay the patient's down arm across it with their palms facing up. Place a light purple arm board strap between the patient's wrist and elbow. Secure the strap around the arm board, arm board pad, and patient's arm.
7. If using Arm Protectors, place One-Step™ Trendelenburg Arm Protectors beneath the patient's arm, centering the arm protector laterally with straps facing down and inward toward the patient's torso. The pad should extend above the elbow and just below the fingertips. The hand should be positioned in a natural anatomical position with the palms facing inward so as not to impinge upon the ulnar nerve. (figure 2-7)

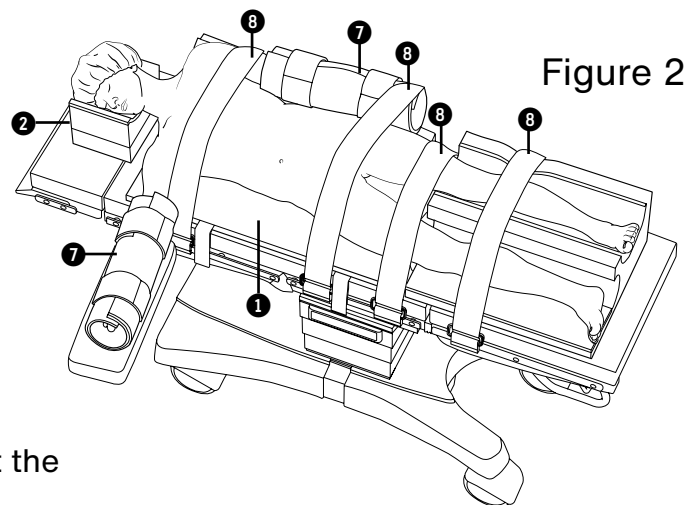

(more information and warnings on reverse side)

8. Use remaining body straps to secure the patient at locations the surgeon prefers or per hospital protocol. Attached body straps by following the steps below:
- Secure both portions of the two-part body strap to the accessory rails.
  - Identify each portion of the strap – Part A has a small Velcro square and Part B has a long Velcro tab. (figure 3)
  - Beginning with Part A, orient the strap so that the small Velcro square is facing outward, away from the table. Draw the end of the belt up between the table and the accessory rail and lay the free end over the table.
  - Repeat the procedure with Part B of the strap on the other side of the table, ensuring that the hook side of the long Velcro tab is facing inward toward the pad.
  - Join straps together with the long Velcro tab of Part B on top of Part A.
9. Tilt O.R. table at the desired angle and begin the procedure.

Figure 3

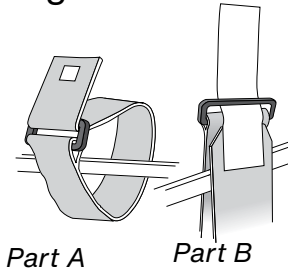

### ATTENTION:

- Before using The Pink Lat Pack™, ensure that the O.R. table pad is securely affixed to the O.R. table and is clean and free of residue
- Be sure to follow your facility's policies and guidelines for frequency of patient monitoring. Check skin for integrity and proper circulation. Product is to be used by licensed medical professionals only.
- Care should be taken to safeguard The Pink Lat Pack™ from exposure to prep solutions.
- Handling & Storage: During ALL handling and storage, assure that the pad is flat. Do not roll or fold the pad.



702 Prominence Drive  
Pittsburgh, PA 15068 U.S.A.

Tel: 724.337.5500  
Fax: 724.337.0555

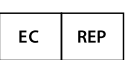

xodusmedical.com  
info@xodusmedical.com

FDA REGISTERED  
ISO 13485 CERTIFIED



xodusmedical.com/eifu

EMERGO EUROPE  
Prinsessegracht 20  
2514 AP The Hague  
The Netherlands